



Vacumobil 200

Dust extractor

4,0 kW (IE3)

H3 zertifiziert

HÖCKER[®]
POLYTECHNIK

Always one idea ahead

Vacumobil 200

Enhanced performance, reduced consumption.

The innovative Vacumobil 200 dedusters by Höcker Polytechnik set entirely new standards in extraction for wood processing machines and air filtration. They feature numerous improvements in regards to energy efficiency, equipment size, performance characteristics and application flexibility. Various filter cleaning processes and the powerful suction make the Vacumobil 200 a reliable filter solution for your company.

Higher throughput is achieved by a housing interior optimised for airflow. Standard energy-saving drives (IE3) reduce electricity consumption. Two collecting vessels provide more usable volume. The Vacumobil is environmentally friendly to operate, with low energy consumption. Only BG-certified filter material is used.

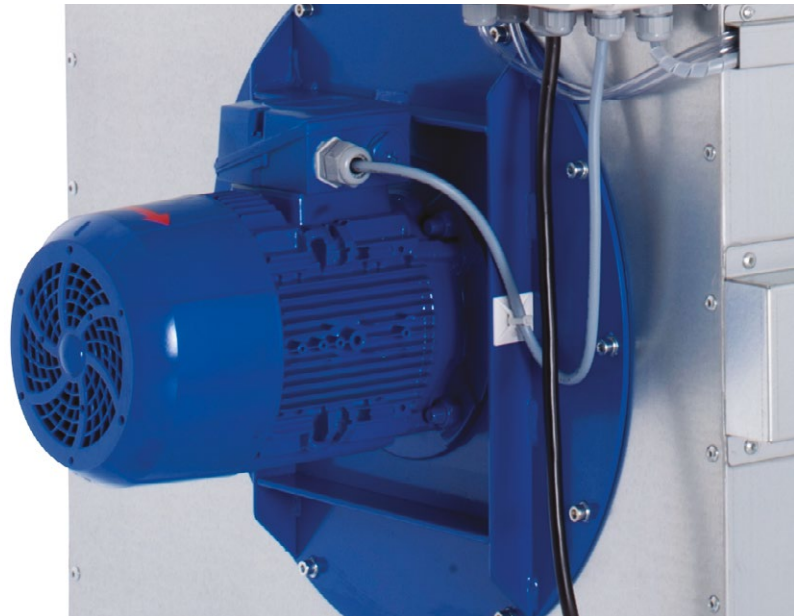

Illustration above:
Vacumobil VT 200 with
4.0 kW energy-saving motor (IE3)

Vacumobil J...

- Ideal for continuous operation (option), since jet filter cleaning with low compressed air consumption ensures effective filter regeneration and long filter life.

Vacumobil V...

- For installation in the shop, also for explosion-prone dust-air mixtures and intermittent processes; during breaks, the system gently cleans the filters by means of vibration without the use of compressed air.

Illustration below: Vacumobil VT 200 with fire suppression system (optional)



Illustration to the right:
PLC controller with text display
and robust membrane keyboard

Safety with a capital S

The Vacumobil can be installed in the shop without additional fire protection measures. It is supplied ready to connect with a phase changing plug. The standard contactor control ensures automatic start-up and safe operation. Inputs for automatic start-up using potential-free contacts are included as standard equipment.

- Pre-separator with intake port Diameter 200 mm (220 mm when dismantling the socket)

- Heat recovery through air recirculation system with noise suppression hood



- PLC controller with text display
- Robust and ergonomic
- Includes rubber cable and phase changing switch
- Energy-saving operation at 4,0 kW



- Robust, ergonomic collecting vessels with foil bags
- More useable volume, longer operating time

- Sturdy duct for negative pressure equalisation
- Reliably holds the foil bags in the collecting vessels

- Sturdy, industrial-grade fixed and steering rollers

Advantages

- Installation in the work area is allowable (depending on the type of dust)
- Low residual dust content < 0.1 mg/m³ (H3) according to the Technical Guideline for the Handling of Hazardous Materials (TRGS) 553
- 100% utilisation of heat energy through air recirculation
- Large collection volume with 2 mobile collecting bins
- Online filter cleaning available (surcharge)
- Low height, less than 2 m (height, middle of intake port: 1.5 m)
- PLC controller, standard with automatic start-up and text display
- Drive Efficiency Class IE3 automatic filter cleaning, optionally motor-driven or with compressed air
- No pressure relief required for St1 dust
- Filter material tested by the Employer's Liability Insurance Association (BG) (99.95% separation)
- Low energy consumption and high extraction performance

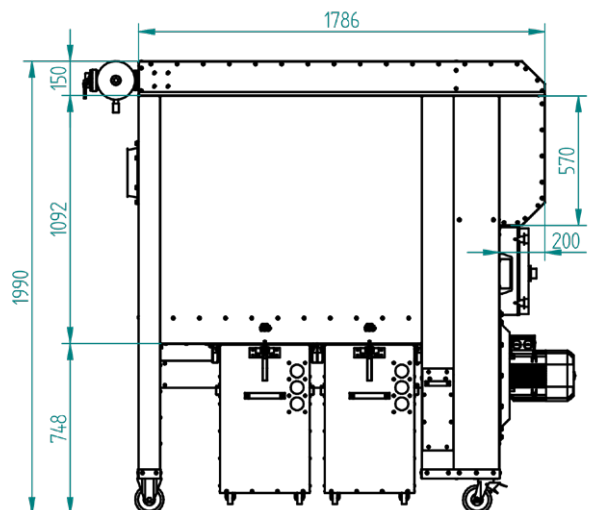
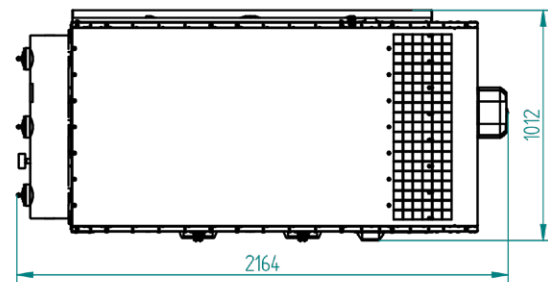

	Vacumobil JT 200	Vacumobil VT 200
Suction connection diameter	200 mm (220 mm without socket)	200 mm (220 mm without socket)
Engine-rating	4,0 kW / 400 V / 50 Hz (IE 3)	4,0 kW / 400 V / 50 Hz (IE 3)
Filter area	ca. 12 m ²	ca. 12 m ²
Nom. Volume Flow (V Nom)	2.260 m ³ /h at 20 m/s	2.260 m ³ /h at 20 m/s
Max. Volume Flow (V Max)	3.400 m ³ /h	3.400 m ³ /h
Vacuum generated V Nom**	ca. 3.500 Pa	ca. 3.500 Pa
Vacuum generated V Max**	ca. 2.700 Pa	ca. 2.700 Pa
Collection Volume	ca. 350 Liter max.	ca. 350 Liter max.
Maximum sound pressure level*	≤ 71 dB(A)	≤ 71 dB(A)
Measurements (L x W x H)	2.160 x 1.020 x 1.990 mm	1.970 x 1.020 x 1.990 mm
Weight	ca. 450 kg	ca. 410 kg
Dedusting	Pressurized air (offline)***	Vibration (automatically with added running times)
Slide valve gear	standard	standard

* Measured according to the EU Machinery Directive subject to free field conditions with 1 m distance of 1.6 m height ** in delivery status - non-impinged filter hoses

*** online cleaning optional (in case of explosive dust - air mixtures only permissible with further protective measures)



Höcker Polytechnik GmbH
Borgloher Straße 1
49176 Hilter a.T.W.
Germany

phone +49 5409 405 0
email info@hpt.net



www.hoecker-polytechnik.com

HÖCKER[®]
POLYTECHNIK

Always one idea ahead